



中国认可  
国际互认  
检测  
TESTING  
CNAS L7649



# EMC TEST REPORT

Report No.: STS2210086E01

Issued for

Key Technology (China) Limited

B703, Building 1, Tianan Cyber Park, Huang Ge North Rd,  
Longcheng Subdistrict, Long Gang District, ShenZhen,

Guang Dong, P.R.China.Zip Code: 518172

Product Name:	Drawer keyboard
Brand:	N/A
Model Number:	K-TEK-A320KP-FN-A83TP-B4-SJ
Series Model(s):	N/A
Test Standard:	IEC 61000-6-2:2016 EN IEC 61000-3-2:2019/A1:2021 IEC 61000-3-3:2013+AMD2:2021 IEC 61000-6-4:2018

Any reproduction of this document must be done in full. No single part of this document may be reproduced without permission from STS, All Test Data Presented in this report is only applicable to presented Test sample.





TEST REPORT CERTIFICATION

Applicant's Name.....: Key Technology (China) Limited
Address .....: B703, Building 1, Tianan Cyber Park, Huang Ge North Rd, Longcheng Subdistrict, Long Gang District, ShenZhen, Guang Dong, P.R.China. Zip Code: 518172
Manufacturer's Name.....: Key Technology (China) Limited
Address .....: Floor 7, Building S8, Fenggang Tianan Cyber Park, No. 208 Fenggang Section, Dongshen Road, Fenggang Town, DongGuan City, Guang Dong Province, P.R. China. Zip Code: 523703

Product Description.....:
Product Name.....: Drawer keyboard
Brand .....: N/A
Model Number .....: K-TEK-A320KP-FN-A83TP-B4-SJ
Series Model(s).....: N/A
Standards .....: IEC 61000-6-2:2016
EN IEC 61000-3-2:2019/A1:2021
IEC 61000-3-3:2013+AMD2:2021
IEC 61000-6-4:2018

This report shall not be reproduced except in full, without the written approval of STS, this document may be altered or revised by STS, personal only, and shall be noted in the revision of the document.

Date of Test .....:
Date of Receipt of Test Item .....: 24 Oct. 2022
Date (s) of Performance of Tests .....: 24 Oct. 2022~ 28 Oct. 2022
Date of Issue .....: 28 Oct. 2022
Test Result.....: Pass

Testing Engineer : Jane.chen
(Jane Chen)

Technical Manager : Bulun
(Bulun)

Authorized Signatory : Bovey Yang
(Bovey Yang)





## TABLE OF CONTENTS

<b>1. TEST SUMMARY</b>	<b>5</b>
1.1 TEST FACTORY	6
1.2 MEASUREMENT UNCERTAINTY	6
<b>2. GENERAL INFORMATION</b>	<b>7</b>
2.1 GENERAL DESCRIPTION OF THE EUT	7
2.2 DESCRIPTION OF THE TEST MODES	8
2.3 DESCRIPTION OF THE TEST SETUP	9
2.4 MEASUREMENT INSTRUMENTS LIST	10
<b>3. EMC EMISSION TEST</b>	<b>13</b>
3.1 CONDUCTED EMISSION MEASUREMENT	13
3.2 RADIATED EMISSION MEASUREMENT	17
3.3 HARMONICS CURRENT	21
3.4 VOLTAGE FLUCTUATION AND FLICKERS	24
<b>4. EMC IMMUNITY TEST</b>	<b>26</b>
4.1 STANDARD COMPLIANCE/SERVURITY LEVEL/CRITERIA	26
4.2 GENERAL PERFORMANCE CRITERIA	27
4.3 ELECTROSTATIC DISCHARGE IMMUNITY TEST (ESD)	28
4.4 RADIATED, RADIO-FREQUENCY, ELECTROMAGNETIC FIELD IMMUNITY TEST (RS)	34
4.5 ELECTRICAL FAST TRANSIENT (EFT)	37
4.6 SURGE TESTING	41
4.7 CONDUCTED RADIO FREQUENCY DISTURBANCES (CS)	44
4.8 VOLTAGE INTERRUPTION/DIPS TESTING (DIPS)	47
<b>APPENDIX 1- TEST SETUP</b>	<b>49</b>



**Revision History**

Rev.	Issue Date	Report No.	Effect Page	Contents
00	28 Oct. 2022	STS2210086E01	ALL	Initial Issue





## 1. TEST SUMMARY

Test procedures according to the technical standards:

EMC Emission				
Standard	Test Item	Limit	Judgment	Remark
IEC 61000-6-2:2016	Conducted Emission on AC And Telecom Port 150kHz to 30MHz	Class A	PASS	
	Radiated Emission 30MHz to 1000MHz	Class A	PASS	
	Radiated Emission 1GHz to 6GHz	Class A	N/A	<b>NOTE (1)</b>
EN IEC 61000-3-2:2019/A1:2021	Harmonic Current Emission	-----	N/A	<b>NOTE (2)</b>
IEC 61000-3-3:2013+AMD2:2021	Voltage Fluctuations & Flicker	-----	PASS	
EMC Immunity				
Section	Test Item	Performance Criteria	Judgment	Remark
IEC 61000-6-4:2018				
IEC 61000-4-2:2008	Electrostatic discharges	B	PASS	
IEC 61000-4-3:2020	Continuous RF electromagnetic field disturbances	A	PASS	
IEC 61000-4-4:2012	Electrical fast transients/burst	B	PASS	
IEC 61000-4-5:2014/A1:2017	Surges	B	PASS	
IEC 61000-4-6:2013	Continuous induced RF disturbances	A	PASS	
IEC 61000-4-8:2009	Power frequency magnetic field	A	N/A	
IEC 61000-4-11:2020	Voltage dips and interruptions	B / C / C	PASS	<b>NOTE (3)</b>

**Note:** (1) If the highest frequency of the internal sources of the EUT is less than 108 MHz, the measurement shall only be made up to 1 GHz.

If the highest frequency of the internal sources of the EUT is between 108 MHz and 500 MHz, the measurement shall only be made up to 2 GHz.

If the highest frequency of the internal sources of the EUT is between 500 MHz and 1GHz, the measurement shall only be made up to 5 GHz.

If the highest frequency of the internal sources of the EUT is above 1 GHz, the measurement shall be made up to 5 times of the highest frequency or 6 GHz, whichever is less.

(2) The power consumption of EUT is less than 75W and no Limits apply.

(3) Voltage Dip: 100% reduction – Performance Criteria **B**

Voltage Dip: 30% reduction – Performance Criteria **C**

Voltage Interruption: 100% Interruption – Performance Criteria **C**

(4) N/A=Not Applicable.





## 1.1 TEST FACTORY

Company Name:	SHENZHEN STS TEST SERVICES CO.,LTD.
Address:	A 1/F, Building B, Zhuoke Science Park, No.190 Chongqing Road, HepingShequ, Fuyong Sub-District, Bao'an District, Shenzhen, Guang Dong, China
Telephone:	+86-755 3688 6288
Fax:	+86-755 3688 6277
Registration No.:	FCC test Firm Registration Number: 625569
	IC test Firm Registration Number: 12108A
	A2LA Certificate No.: 4338.01

## 1.2 MEASUREMENT UNCERTAINTY

The reported uncertainty of measurement  $y \pm U$ , where expanded uncertainty  $U$  is based on a standard uncertainty multiplied by a coverage factor of  $k=2$ , providing a level of confidence of approximately 95 %.

### A. Conducted Measurement:

Test Site	Method	Measurement Frequency Range	U , (dB)	NOTE
STSC01	CISPR 16-4-2	9KHz ~ 30MHz	2.73	

### B. Radiated Measurement:

Test Site	Method	Measurement Frequency Range	U , (dB)	NOTE
STSC02	CISPR 16-4-2	30MHz ~ 1000MHz	4.09	
		1GHz ~ 6 GHz	4.92	



## 2. GENERAL INFORMATION

### 2.1 GENERAL DESCRIPTION OF THE EUT

Product Name	Drawer keyboard
Brand	N/A
Model Number	K-TEK-A320KP-FN-A83TP-B4-SJ
Series Model(s)	N/A
Product Differences	N/A
Product Description	<p>The EUT is a Drawer keyboard.</p> <p>Based on the application, features, or specification exhibited in User's Manual, the EUT is considered as an ITE/Computing Device. More details of EUT technical specification, please refer to the User's Manual.</p>
Rating	Input: DC 5V

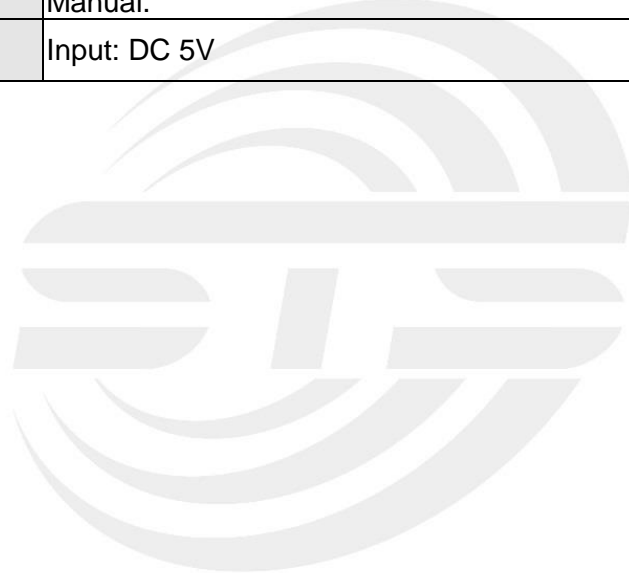



## 2.2 DESCRIPTION OF THE TEST MODES

To investigate the maximum EMI emission characteristics generates from EUT, the test system was pre-scanning tested base on the consideration of following EUT operation mode or test configuration mode which possible have effect on EMI emission level. Each of these EUT operation mode(s) or test configuration mode(s) mentioned above was evaluated respectively.

Pretest Mode	Description
Mode 1	Working

For Conducted Test	
Final Test Mode	Description
Mode 1	Working

For Radiated Test	
Final Test Mode	Description
Mode 1	Working

For EMS Test	
Final Test Mode	Description
Mode 1	Working





### 2.3 DESCRIPTION OF THE TEST SETUP

The EUT has been tested with associated equipment below and the test setup please refer to appendix 1 - test setup

#### Necessary accessories

Item	Equipment	Mfr/Brand	Model/Type No.	Length	Note
/	USB Cable	N/A	N/A	>300cm	NO

#### Support units

Item	Equipment	Mfr/Brand	Model/Type No.	Length	Note
/	Computer Adapter	HP	HSTNN-CA15	N/A	N/A
/	Personal computer	HP	500-320cx	N/A	N/A
/	Mouse	HP	MODGUO	N/A	N/A
/	USB Cable	N/A	N/A	110cm	NO

#### Note:

- (1) For detachable type I/O cable should be specified the length in cm in 『Length』 column.
- (2) “YES” means “with core”; “NO” means “without core”.



## 2.4 MEASUREMENT INSTRUMENTS LIST

### 2.4.1 CONDUCTED TEST SITE

Kind of Equipment	Manufacturer	Type No.	Serial No.	Last Calibration	Calibrated Until
EMI Test Receiver	R&S	ESCI	101427	2022.9.28	2023.9.27
LISN	R&S	AiT-F01220	8130179	2022.9.28	2023.9.27
Absorbing Clamp	R&S	MDS-21	100668	2022.3.2	2023.3.1
CE Cable	N/A	C01	N/A	2022.9.28	2023.9.27
EMF Antenna	SCHWARZBECK	VDHH 9502	147	2022.9.28	2023.9.27
Temperature & Humidity	Mieo	HH660	N/A	2022.9.30	2023.9.29
Testing Software	EZ-EMC(Ver.STSLAB-03A1 CE)				

### 2.4.2 RADIATED TEST SITE

Kind of Equipment	Manufacturer	Type No.	Serial No.	Last Calibration	Calibrated Until
EMI Test Receiver	R&S	ESCI	101427	2022.9.29	2023.9.28
Bi-log Antenna	TESEQ	CBL6111D	45873	2021.10.8	2023.10.7
Horn Antenna	SCHWARZBECK	BBHA 9120D	9120D-1343	2021.9.28	2023.9.27
Pre-amplifier(1G-26.5G)	Agilent	HP8449B	3008A02383	2022.7.4	2023.7.3
Pre-amplifier(0.1M-3GHz)	EM	EM330	060665	2022.7.4	2023.7.3
Spectrum Analyzer	Agilent	N9020A	MY49100060	2022.9.28	2023.9.27
RE Cable (9K-1G)	N/A	R01	N/A	2022.9.28	2023.9.27
RE Cable (1G-26G)	N/A	R02	N/A	2022.9.28	2023.9.27
Temperature & Humidity	Mieo	HH660	N/A	2022.9.30	2023.9.29
Testing Software	EZ-EMC(Ver.STSLAB-03A1 RE)				

### 2.4.3 HARMONICS AND FLICKER

Kind of Equipment	Manufacturer	Type No.	Serial No.	Last Calibration	Calibrated Until
Harmonic Voltage & Flicker	LAPLACE	AC 2000A	311217	2022.9.28	2023.9.27
AC Power Source	MTONI	PHF-5010	631169	2022.9.28	2023.9.27
Temperature & Humidity	Mieo	HH660	N/A	2022.9.30	2023.9.29
Testing Software	HA-PC Link Version 3.03				

**2.4.4 ESD**

Kind of Equipment	Manufacturer	Type No.	Serial No.	Last Calibration	Calibrated Until
ESD TEST GENERATOR	TESEQ	NSG438	1175	2022.9.28	2023.9.27
Temperature & Humidity	N/A	WS1066	N/A	2022.3.2	2023.3.1

**2.4.5 SURGE, EFT/BURST, VOLTAGE INTERRUPTION/DIPS**

Kind of Equipment	Manufacturer	Type No.	Serial No.	Last Calibration	Calibrated Until
Surger Generator	HTEC	HCOMPACT 7	183501	2022.9.28	2023.9.27
Surger Generator	HTEC	HTW	152104	2022.9.28	2023.9.27
VOLTAGE DIPS & INTERRUPTIONS Generator	HTEC	HPFS 161P	143803	2022.3.2	2023.3.1
EFT/B Generator	HTEC	HEFT 51	1920001	2022.9.28	2023.9.27
Temperature & Humidity	Mieo	HH660	N/A	2022.9.30	2023.9.29

**2.4.6 RS**

Kind of Equipment	Manufacturer	Type No.	Serial No.	Last Calibration	Calibrated Until
Power Meter	Agilent	E4419B	QB43312265	2022.9.28	2023.9.27
Power Sensor	hp	E9300A	US39210170	2022.9.28	2023.9.27
Power Sensor	hp	E9300A	US39210476	2022.9.28	2023.9.27
Signal Generator	Agilent	N5181A	MY56144718	2022.9.28	2023.9.27
Power Amplifier	MICOTOP	MPA-80-1000-250	MPA1711489	2022.9.28	2023.9.27
Power Amplifier	MICOTOP	MPA-1000-6000-100	MPA1904132	2022.9.28	2023.9.27
RS Test Antenna (80-1GHz)	SCHWARZBECK	VULP 9118E	000999	N/A	N/A
RS Test Antenna (1G-10GHz)	SCHWARZBECK	STLP 9149	000648	N/A	N/A
Universal Radio Communication Tester	R&S	CMU200	116337	2022.3.2	2023.3.1
Audio Analyzer	R&S	UPL	100689	2022.3.3	2023.3.2
Audio Breakthrough Shielding Box	SKET	SB_ABT/C35	N/A	N/A	N/A
Ear Simulator	SKET	AE_ABT/C35	N/A	N/A	N/A
Mouth Simulator	SKET	AM_ABT/C35	N/A	N/A	N/A
1KHz Standard Source	SKET	MSC_ABT/C35	N/A	2022.9.28	2023.9.27



Field Probe	Narda	EP601	611WX80261	2022.3.2	2023.3.1
Temperature & Humidity	Mieo	HH660	N/A	2022.9.30	2023.9.29
Testing Software	EMC-S V1.4.0.53				

## 2.4.7 INJECTION CURRENT

Kind of Equipment	Manufacturer	Type No.	Serial No.	Last Calibration	Calibrated Until
CS	SCHLODER	CDG-6000-25	126A1280/2014	2022.9.28	2023.9.27
CDN	SCHLODER	CDN-M2+3	A2210275/2014	2022.9.28	2023.9.27
EM Clamp	SCHLODER	EMCL-20	132A1283	2022.9.28	2023.9.27
Attenuator	Nemtest	ATT-6DB-100	A100W224	2022.9.28	2023.9.27
Universal Radio Communication Tester	R&S	CMU200	111058	2022.3.2	2023.3.1
Audio Analyzer	R&S	UPL	100689	2022.3.3	2023.3.2
Audio Breakthrough Shielding Box	SKET	SB_ABT/C35	N/A	N/A	N/A
Ear Simulator	SKET	AE_ABT/C35	N/A	N/A	N/A
Mouth Simulator	SKET	AM_ABT/C35	N/A	N/A	N/A
1KHz Standard Source	SKET	MSC_ABT/C35	N/A	2022.9.28	2023.9.27
Temperature & Humidity	Mieo	HH660	N/A	2022.9.30	2023.9.29



### 3. EMC EMISSION TEST

#### 3.1 CONDUCTED EMISSION MEASUREMENT

##### 3.1.1 POWER LINE CONDUCTED EMISSION

(Frequency Range 150KHz-30MHz)

FREQUENCY (MHz)	Class A (dBuV)		Class B (dBuV)	
	Quasi-peak	Average	Quasi-peak	Average
0.15 -0.5	79.00	66.00	66 - 56 *	56 - 46 *
0.50 -5.0	73.00	60.00	56.00	46.00
5.0 -30.0	73.00	60.00	60.00	50.00

Note:

- (1) The tighter limit applies at the band edges.
- (2) The limit of " \* " marked band means the limitation decreases linearly with the logarithm of the frequency in the range.

The following table is the setting of the receiver

Receiver Parameters	Setting
Attenuation	10 dB
Start Frequency	0.15 MHz
Stop Frequency	30 MHz
IF Bandwidth	9 kHz

### 3.1.2 TEST PROCEDURE

- a. The EUT was placed 0.4 meters from the conducting wall of the shielded room with EUT being connected to the power mains through a line impedance stabilization network (LISN). Other support units were connected to the power mains through another LISN. The two LISNs provide 50 Ohm/ 50uH of coupling impedance for the measuring instrument.
- b. Interconnecting cables that hang closer than 40 cm to the ground plane shall be folded back and forth in the center forming a bundle 30 to 40 cm long.
- c. I/O cables that are not connected to a peripheral shall be bundled in the center. The end of the cable may be terminated, if required, using the correct terminating impedance. The overall length shall not exceed 1 m.
- d. For the actual test configuration, please refer to the related Item –EUT Test Photos.

### 3.1.3 TEST SETUP

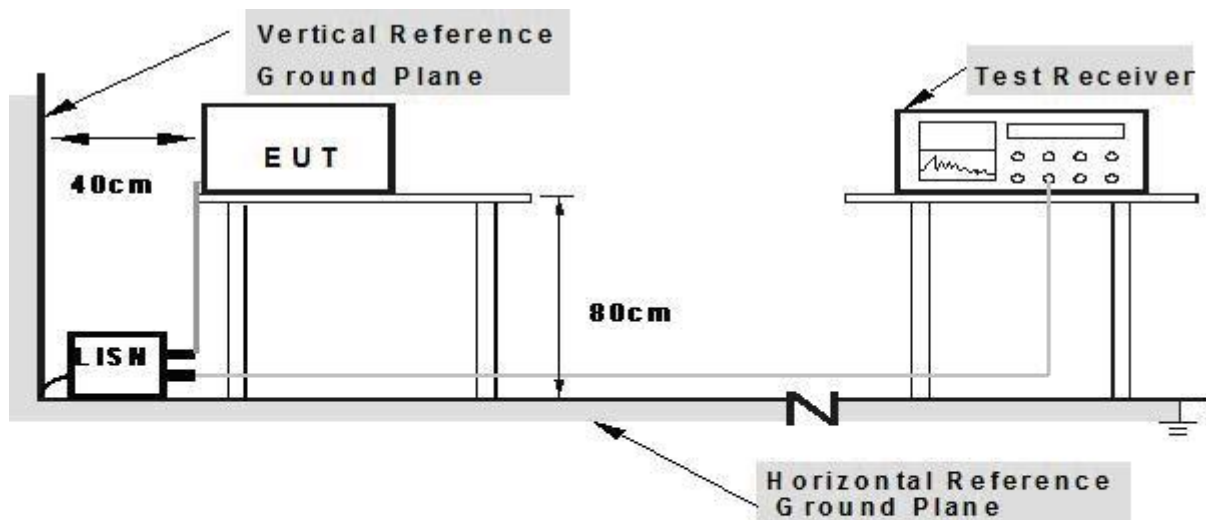

- Note: 1. Support units were connected to second LISN.**  
**2. Both of LISN s (AMN) are 80 cm from EUT and at least 80 cm from other units and other metal planes**

### 3.1.4 EUT OPERATING CONDITIONS

The EUT tested system was configured as the statements of 2.3 Unless otherwise a special operating condition is specified in the following during the testing.





### 3.1.5 TEST RESULTS

Temperature:	23.8°C	Relative Humidity:	44%
Phase:	L	Test Mode:	Mode 1
Test Voltage:	AC 230V/50Hz	Test Date:	2022.10.24

No.	Frequency (MHz)	Reading (dBuV)	Correct Factor (dB)	Result (dBuV)	Limit (dBuV)	Margin (dB)	Detector
1	0.1500	42.61	10.33	52.94	79.00	-26.06	QP
2	0.1500	10.88	10.33	21.21	66.00	-44.79	AVG
3	0.1820	48.54	10.31	58.85	79.00	-20.15	QP
4	0.1820	28.90	10.31	39.21	66.00	-26.79	AVG
5	0.2430	40.67	10.50	51.17	79.00	-27.83	QP
6	0.2430	22.63	10.50	33.13	66.00	-32.87	AVG
7	2.1380	38.75	10.30	49.05	73.00	-23.95	QP
8	2.1380	24.29	10.30	34.59	60.00	-25.41	AVG
9	3.9940	31.80	10.40	42.20	73.00	-30.80	QP
10	3.9940	17.46	10.40	27.86	60.00	-32.14	AVG
11	22.1740	26.32	12.77	39.09	73.00	-33.91	QP
12	22.1740	14.00	12.77	26.77	60.00	-33.23	AVG

Remark:

1. All readings are Quasi-Peak and Average values
2. Margin = Result (Result = Reading + Factor) – Limit
3. Factor = Insertion loss + Cable loss

100.0 dBuV

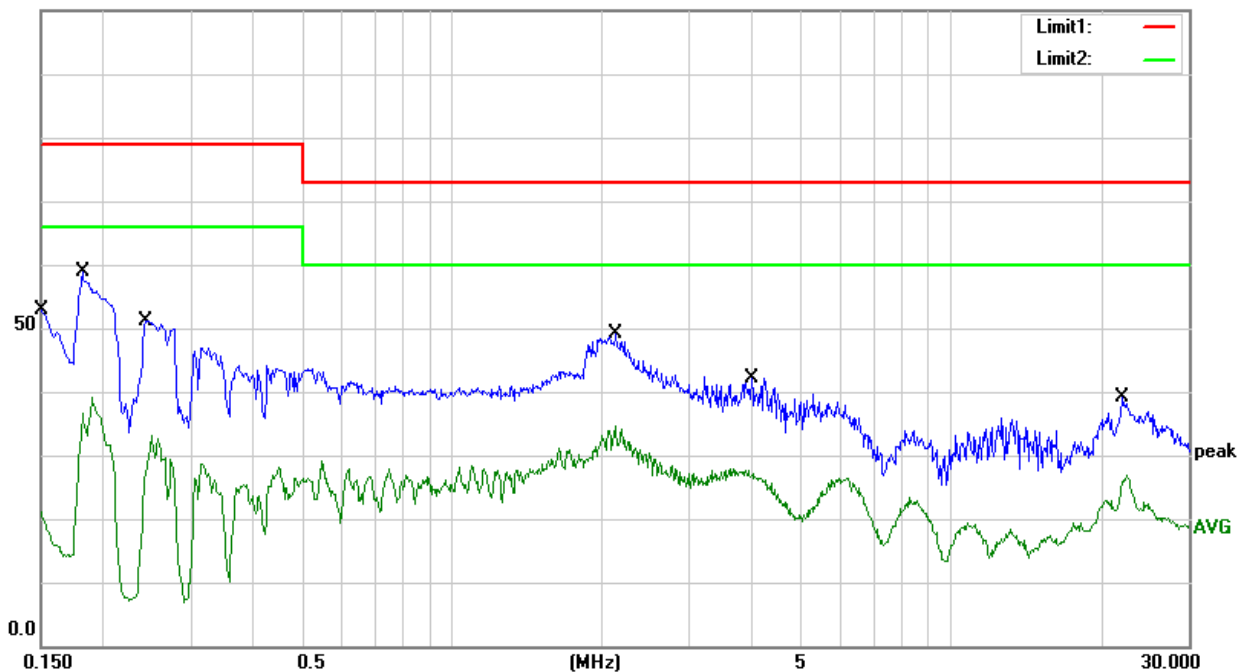



Temperature:	23.8°C	Relative Humidity:	44%
Phase:	N	Test Mode:	Mode 1
Test Voltage:	AC 230V/50Hz	Test Date:	2022.10.24

No.	Frequency (MHz)	Reading (dBuV)	Correct Factor (dB)	Result (dBuV)	Limit (dBuV)	Margin (dB)	Detector
1	0.1500	42.67	10.29	52.96	79.00	-26.04	QP
2	0.1500	8.78	10.29	19.07	66.00	-46.93	AVG
3	0.1860	48.73	10.37	59.10	79.00	-19.90	QP
4	0.1860	30.58	10.37	40.95	66.00	-25.05	AVG
5	0.2500	38.91	10.60	49.51	79.00	-29.49	QP
6	0.2500	20.00	10.60	30.60	66.00	-35.40	AVG
7	2.1260	38.60	10.39	48.99	73.00	-24.01	QP
8	2.1260	24.25	10.39	34.64	60.00	-25.36	AVG
9	4.1860	31.71	10.52	42.23	73.00	-30.77	QP
10	4.1860	17.53	10.52	28.05	60.00	-31.95	AVG
11	22.5740	25.98	12.82	38.80	73.00	-34.20	QP
12	22.5740	14.24	12.82	27.06	60.00	-32.94	AVG

Remark:

1. All readings are Quasi-Peak and Average values
2. Margin = Result (Result = Reading + Factor) - Limit
3. Factor = Insertion loss + Cable loss

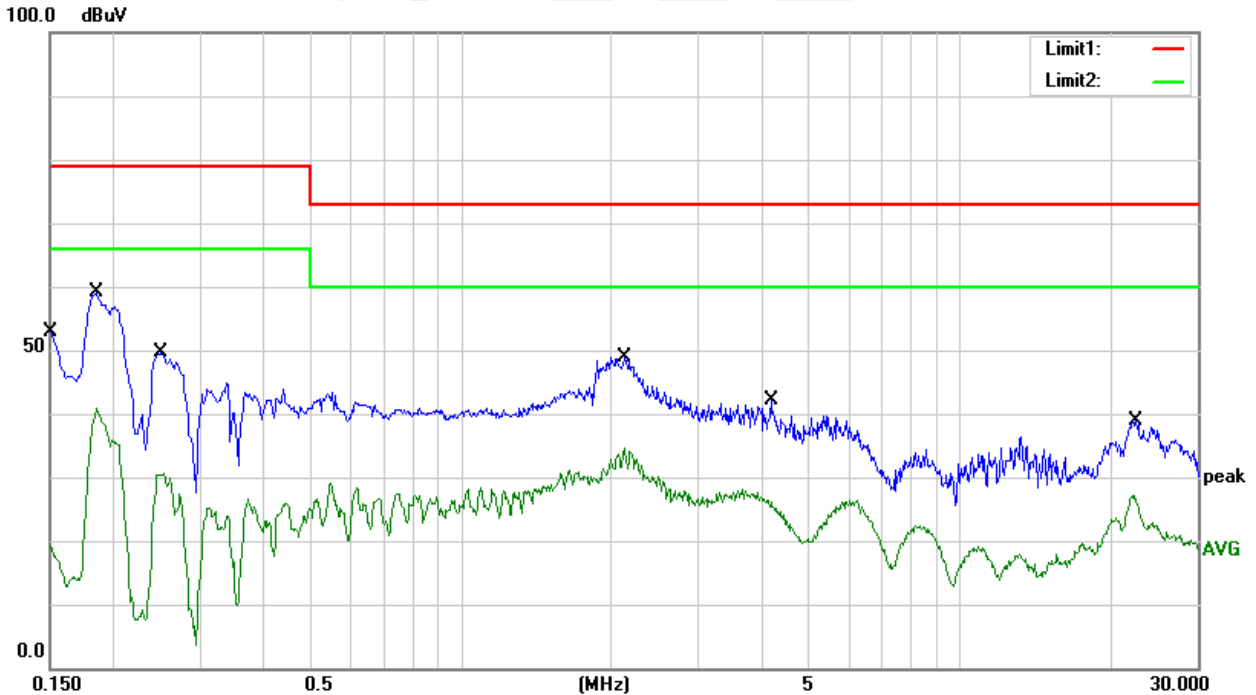



## 3.2 RADIATED EMISSION MEASUREMENT

### 3.2.1 LIMITS OF THE RADIATED EMISSION MEASUREMENT (Below 1000MHz)

FREQUENCY (MHz)	Class A		Class B	
	At 10m	At 3m	At 10m	At 3m
	dBuV/m	dBuV/m	dBuV/m	dBuV/m
30 – 230	40	50	30	40
230 – 1000	47	57	37	47

### 3.2.2 LIMITS OF THE RADIATED EMISSION MEASUREMENT (Above 1000MHz)

FREQUENCY (MHz)	Class A (at 3m) dBuV/m		Class B (at 3m) dBuV/m	
	Peak	Avg	Peak	Avg
1000-3000	76	56	70	50
3000-6000	80	60	74	54

Notes:

- (1) The limit for radiated test was performed in the following: CISPR 32.
- (2) The tighter limit applies at the band edges.
- (3) Emission level (dBuV/m) = 20log Emission level (uV/m).

### 3.2.3 TEST PROCEDURE

- a. The EUT was placed on the top of a rotating table 0.8 meters above the ground at a 3 meter semi-anechoic chamber room. The table was rotated 360 degrees to determine the position of the highest radiation.
- b. EUT as the center to the edge of the auxiliary device, the distance from the maximum edge to the center of the antenna is 3 meters.
- c. The height of antenna is varied from 1 meter to 4 meters above the ground to determine the maximum value of the field strength. Both horizontal and vertical polarizations of the antenna are set to make the measurement.
- d. For each suspected emission, the EUT was arranged to its worst case and then the antenna was tuned to heights from 1 meter to 4 meters and the rotatable table was turned from 0 degrees to 360 degrees to find the maximum reading.
- e. The test-receiver system was set to quasi-peak detect function and specified bandwidth with maximum hold mode when the test frequency is below 1GHz.
- f. For the actual test configuration, please refer to the related Item –EUT Test Photos.

### 3.2.4 TEST SETUP

(A) Radiated Emission Test Set-Up Frequency Below 1 GHz

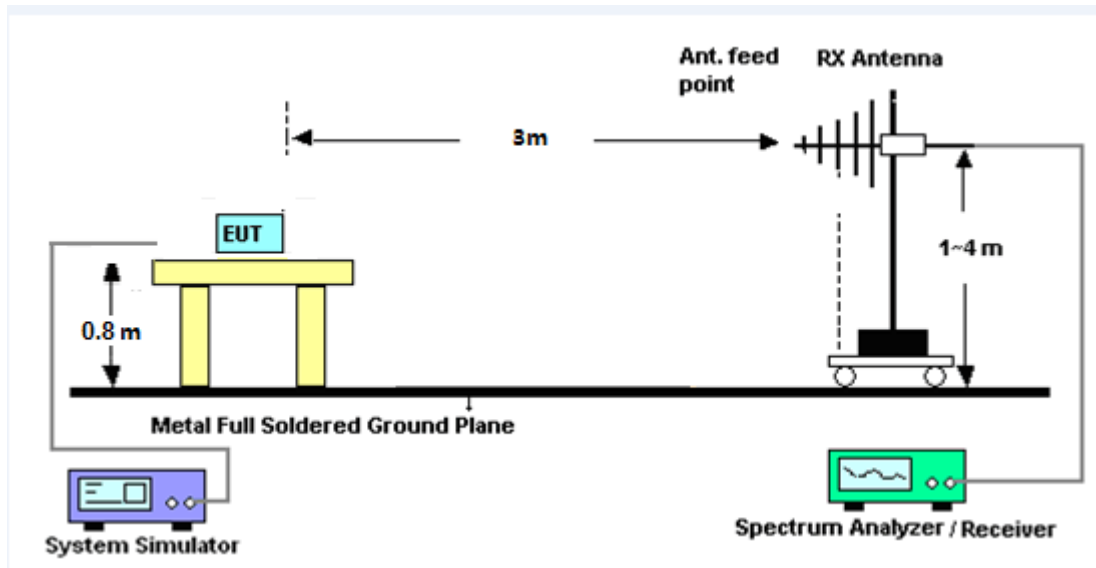

(B) Radiated Emission Test Set-Up Frequency Above 1GHz

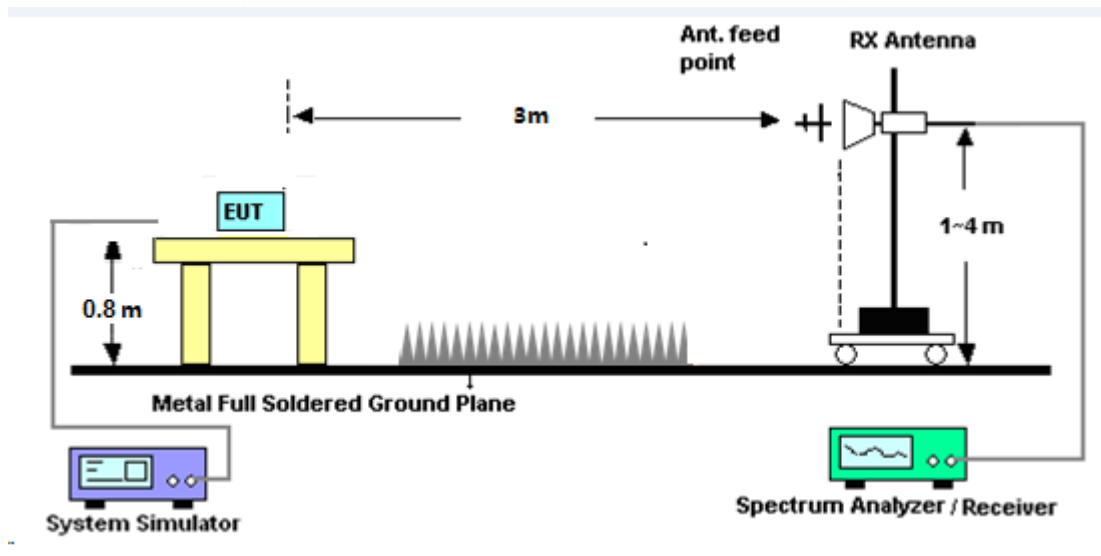

### 3.2.5 EUT OPERATING CONDITIONS

The EUT tested system was configured as the statements of 2.3 Unless otherwise a special operating condition is specified in the following during the testing.



### 3.2.6 TEST RESULTS

Temperature:	25.6°C	Relative Humidity:	58%
Phase:	Horizontal	Test Mode:	Mode 1
Test Voltage:	DC 5V	Test Date:	2022.10.24

No.	Frequency (MHz)	Reading (dBuV)	Correct Factor (dB)	Results (dBuV/m)	Limit (dBuV/m)	Margin (dB)	Detector
1	30.5306	40.20	-11.32	28.88	50.00	-21.12	QP
2	62.8708	60.86	-25.94	34.92	50.00	-15.08	QP
3	225.3080	52.36	-19.10	33.26	50.00	-16.74	QP
4	257.4222	47.40	-15.38	32.02	57.00	-24.98	QP
5	750.1083	35.31	-4.93	30.38	57.00	-26.62	QP
6	1000.0000	35.19	-2.19	33.00	57.00	-24.00	QP

Remark:

1. All readings are Quasi-Peak
2. Margin = Result (Result =Reading + Factor)–Limit
3. Factor= Cable Loss +Antenna Factor–Amplifier Gain

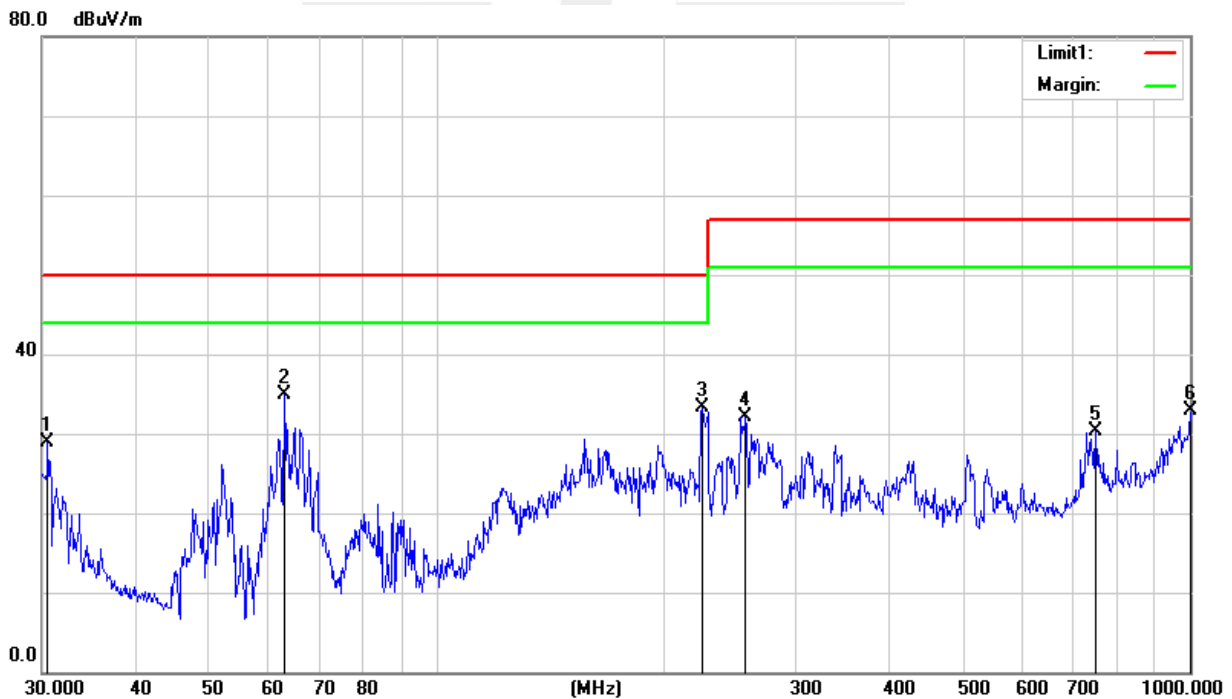



Temperature:	25.6°C	Relative Humidity:	58%
Phase:	Vertical	Test Mode:	Mode 1
Test Voltage:	DC 5V	Test Date:	2022.10.24

No.	Frequency (MHz)	Reading (dBuV)	Correct Factor (dB)	Results (dBuV/m)	Limit (dBuV/m)	Margin (dB)	Detector
1	30.4238	54.03	-11.26	42.77	50.00	-7.23	QP
2	52.0251	55.97	-22.51	33.46	50.00	-16.54	QP
3	76.2442	55.37	-24.13	31.24	50.00	-18.76	QP
4	119.4361	49.72	-18.32	31.40	50.00	-18.60	QP
5	226.0994	49.22	-19.03	30.19	50.00	-19.81	QP
6	996.4996	35.46	-2.16	33.30	57.00	-23.70	QP

Remark:

- 1. All readings are Quasi-Peak
- 2. Margin = Result (Result = Reading + Factor)–Limit
- 3. Factor= Cable Loss +Antenna Factor–Amplifier Gain

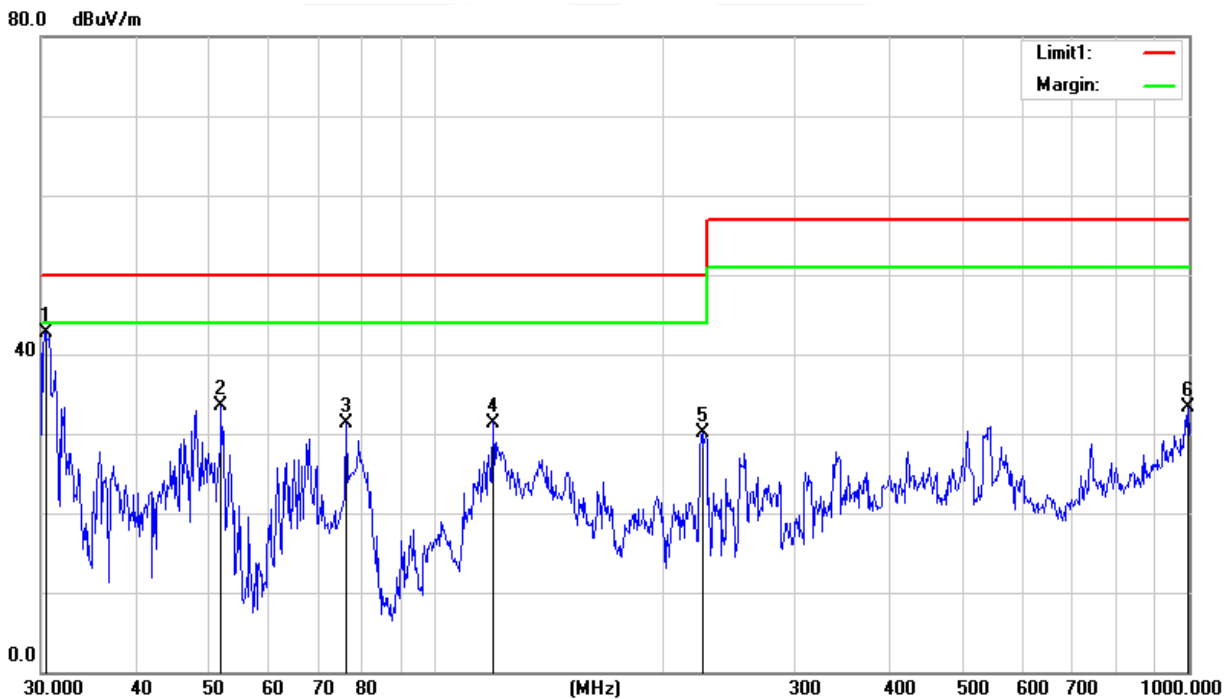





### 3.3 HARMONICS CURRENT

#### 3.3.1 LIMITS OF THE HARMONICS CURRENT

IEC 555-2					
Table - I			Table - II		
Equipment Category	Harmonic Order n	Max. Permissible Harmonic Current (in Amperes)	Equipment Category	Harmonic Order n	Max. Permissible Harmonic Current (in Amperes)
Non Portable Tools or TV Receivers	Odd Harmonics		TV Receivers	Odd Harmonics	
	3	2.30		3	0.80
	5	1.14		5	0.60
	7	0.77		7	0.45
	9	0.40		9	0.30
	11	0.33		11	0.17
	13	0.21		13	0.12
	15 ≤ n ≤ 39	0.15 · 15/n		15 ≤ n ≤ 39	0.10 · 15/n
	Even Harmonics			Even Harmonics	
	2	1.08		2	0.30
4	0.43	4	0.15		
8	0.30				
8 ≤ n ≤ 40	0.23 · 8/n	DC	0.05		

EN 61000-3-2/IEC 61000-3-2					
Equipment Category	Max. Permissible Harmonic Current (in Amperes)	Equipment Category	Harmonic Order n	Max. Permissible Harmonic Current (in A) (mA/w)	
Class A	Same as Limits Specified in 4-2.1, Table - I, but only odd harmonics required	Class D	3	2.30	3.4
			5	1.14	1.9
			7	0.77	1.0
			9	0.40	0.5
			11	0.33	0.35
			13 ≤ n ≤ 39	see Table I	3.85/n

### 3.3.2 TEST PROCEDURE

a. The EUT was placed on the top of a wooden table 0.8 meters above the ground and operated to produce the maximum harmonic components under normal operating conditions.

b. The classification of EUT is according to section 5 of EN 61000-3-2. The EUT is classified as follows:

Class A: Balanced three-phase equipment, Household appliances excluding equipment as Class D, Tools excluding portable tools, Dimmers for incandescent lamps, audio equipment, equipment not specified in one of the three other classes.

Class B: Portable tools. Portable tools; Arc welding equipment which is not professional equipment.

Class C: Lighting equipment.

Class D: Equipment having a specified power less than or equal to 600W of the following types: Personal computers and personal computer monitors and television receivers.

c. The correspondent test program of test instrument to measure the current harmonics emanated from EUT is chosen. The measure time shall be not less than the time necessary for the EUT to be exercised.

### 3.3.3 EUT OPERATING CONDITIONS

The EUT tested system was configured as the statements of 2.3 Unless otherwise a special operating condition is specified in the following during the testing.

### 3.3.4 TEST SETUP

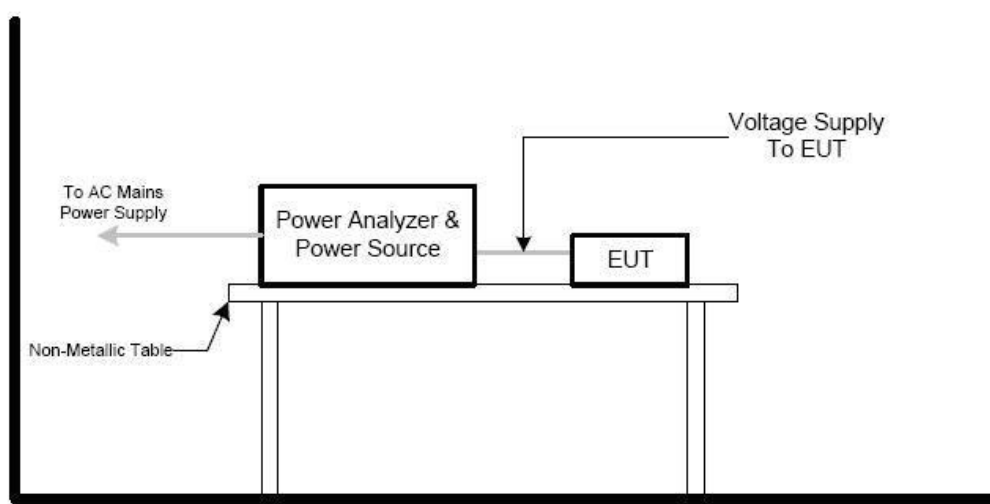



### 3.3.5 TEST RESULTS

Temperature:	26°C	Relative Humidity:	45%
Test Voltage:	N/A	Test Date:	N/A

*Note: The above limits for all equipment except for lighting equipment having an active input power >75 W and no limits apply for equipment with an active input power up to and including 75W..*



### 3.4 VOLTAGE FLUCTUATION AND FLICKERS

#### 3.4.1 LIMITS OF THE VOLTAGE FLUCTUATION AND FLICKERS

Tests	Measurement Value	Limit	Descriptions
	IEC555-3	IEC/EN 61000-3-3	
P <sub>st</sub>	≤ 1.0, T <sub>p</sub> = 10 min.	≤ 1.0, T <sub>p</sub> = 10 min.	Short Term Flicker Indicator
P <sub>lt</sub>	N/A	≤0.65, T <sub>p</sub> =2 hr.	Long Term Flicker Indicator
T <sub>dt(s)</sub>	≤ 3%	≤ 3.3%	Relative Steady-State V-Chang
d <sub>max</sub> (%)	≤ 4%	≤ 4%	Maximum Relative V-Chang
d <sub>c</sub> (%)	N/A	≤ 3.3% for > 500ms	Relative V-change Characteristic

#### 3.4.2 TEST PROCEDURE

a. Fluctuation and Flickers Test:

Tests was performed according to the Test Conditions/Assessment of Voltage Fluctuations specified in Clause 5.0/6.0 of IEC555-3 and/or Clause 6.0/4.0 of IEC/EN 61000-3-3 depend on which standard adopted for compliance measurement.

b. All types of voltage fluctuation in this report are assessed by direct measurement using flicker-meter.

#### 3.4.3 EUT OPERATING CONDITIONS

The EUT tested system was configured as the statements of 2.3 Unless otherwise a special operating condition is specified in the following during the testing.

#### 3.4.4 TEST SETUP

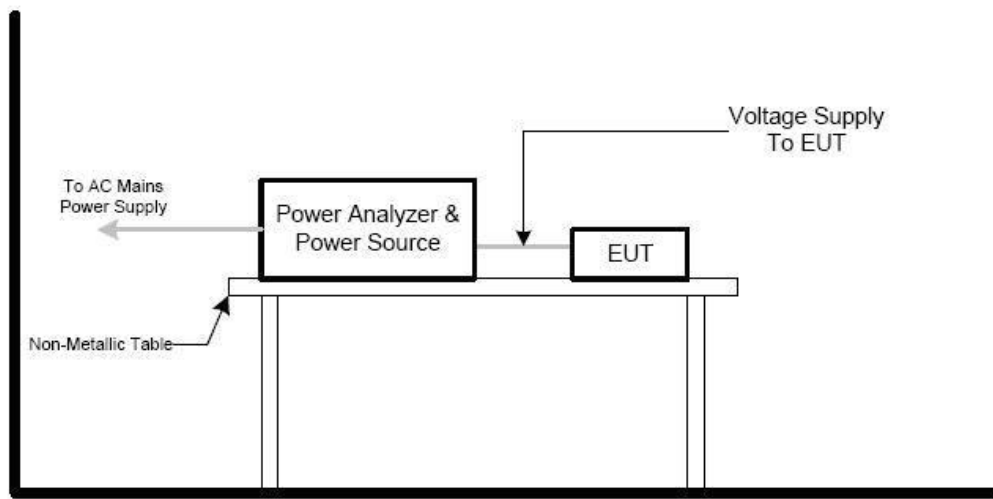



### 3.4.5 TEST RESULTS

EUT: Drawer keyboard  
 Test category: IEC 61000-3-3:2013+AMD2:2021  
 Measurement standard: IEC 61000-15 Ed2.0:2010  
 Test date:2022-10-26      Start time: 11:38:16  
 Test duration (sec):600  
 Describe:

Operator: STAR  
 Model/Type:K-TEK-A320KP-FN-A83TP-B4-SJ  
 Serial number:  
 End time: 11:48:17

Load Power           : 0.056 kW                      Power Factor:0.444  
 Load Current       : 0.216 Arms                      Crest Factor:4.102  
 Nominal Voltage    : 229.85 Vrms

Test Result: pass                      Status: Test Completed

Psti and limit line                      European Limits

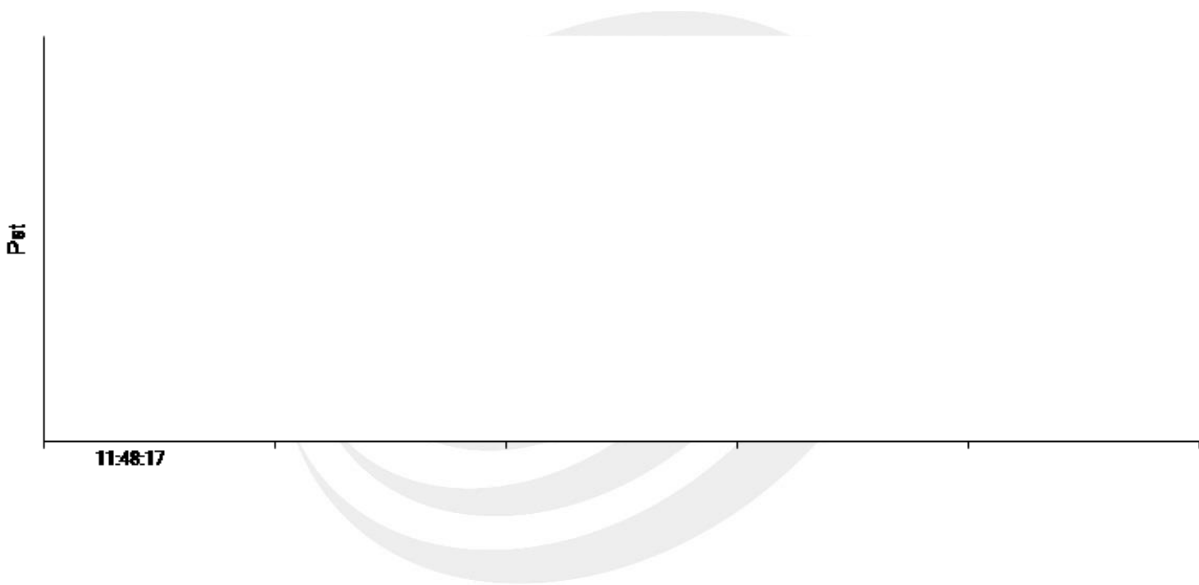

**Result:**

T-max (ms):	0.00	Test limit (ms):	500.00	Pass
Highest dc (%):	0.00	Test limit (%):	3.30	Pass
Highest dmax (%):	0.00	Test limit (%):	4.00	Pass
Highest Pst (10 min. period):	0.00	Test limit:	1.00	Pass



## 4. EMC IMMUNITY TEST

### 4.1 STANDARD COMPLIANCE/SERVIRITY LEVEL/CRITERIA

Tests Standard No.	TEST SPECIFICATION	Test Mode Test Ports	Perform. Criteria
1. ESD IEC/EN 61000-4-2	8KV air discharge 4KV contact discharge	Direct Mode	B
	4KV HCP discharge 4KV VCP discharge	Indirect Mode	B
2. RS IEC/EN 61000-4-3	80 MHz to 1000 MHz, 1000Hz, 80%, AM modulated	Enclosure	A
3. EFT/Burst IEC/EN 61000-4-4	5/50ns Tr/Th 5KHz Repetition Freq.	Power Supply Port	B
	5/50ns Tr/Th 5KHz Repetition Freq.	CTL/Signal Data Line Port	B
4. Surges IEC/EN 61000-4-5	1.2/50(8/20) Tr/Th us	L-N	B
	1.2/50(8/20) Tr/Th us	L-PE N-PE	B
5. Injected Current IEC/EN 61000-4-6	0.15 MHz to 80 MHz, 1000Hz 80%, AM Modulated 150Ω source impedance	CTL/Signal Port	A
	0.15 MHz to 80 MHz, 1000Hz 80%, AM Modulated 150Ω source impedance	AC Power Port	A
	0.15 MHz to 80 MHz, 1000Hz 80%, AM Modulated 150Ω source impedance	DC Power Port	A
6. Volt. Interruptions Volt. Dips IEC/EN 61000-4-11	Voltage dip 100%	AC Power Port	B
	Voltage dip 30%		C
	Interruption 100%		C





## 4.2 GENERAL PERFORMANCE CRITERIA

According to **EN 61000-6-2** standard, the general performance criteria as following:

<b>Criterion A</b>	The apparatus shell continues to operate as intended without operator intervention. No degradation of performance or loss of function is allowed below a performance level specified by the manufacturer, when the apparatus is used as intended. The performance level may be replaced by a permissible loss of performance. If the manufacturer does not specify the minimum performance level or the permissible performance loss, then either of these may be derived from the product description and documentation, and by what the user may reasonably expect from the equipment if used as intended.
<b>Criterion B</b>	<p>After test, the apparatus shell continues to operate as intended without operator intervention. No degradation of performance or loss of function is allowed, after the application of the phenomenon below a performance level specified by the manufacturer, when the apparatus is used as intended. The performance level may be replaced by a permissible loss of performance.</p> <p>During the test, degradation of performance is however allowed. However, no change of operating state if stored data is allowed to persist after the test. If the manufacturer does not specify the minimum performance level or the permissible performance loss, then either of these may be derived from the product description and documentation, and by what the user may reasonably expect from the equipment if used as intended.</p>
<b>Criterion C</b>	<p>Temporary loss of function is allowed, provided the functions is self-recoverable or can be restored by the operation of controls by the user in accordance with the manufacturer instructions.</p> <p>Functions, and/or information stored in non-volatile memory, or protected by a battery backup, shall not be lost.</p>

### 4.2.1 GENERAL PERFORMANCE CRITERIA TEST SETUP

The EUT tested system was configured as the statements of **2.3** Unless otherwise a special operating condition is specified in the following during the testing.



### 4.3 ELECTROSTATIC DISCHARGE IMMUNITY TEST (ESD)

#### 4.3.1 TEST SPECIFICATION

Basic Standard:	IEC/EN 61000-4-2
Discharge Impedance:	330 ohm / 150 pF
Required Performance:	B
Discharge Voltage:	Air Discharge : 2KV/4KV/8KV (Direct) Contact Discharge : 2KV/4KV (Direct/Indirect)
Polarity:	Positive & Negative
Number of Discharge:	Air Discharge: min. 20 times at each test point Contact Discharge: min. 200 times in total 50 times at each test point
Discharge Mode:	Single Discharge
Discharge Period:	1 second minimum

#### 4.3.2 TEST PROCEDURE

The test generator necessary to perform direct and indirect application of discharges to the EUT in the following manners:

- a. Electrostatic discharges were applied only to those points and surfaces of the EUT that are accessible to users during normal operation  
The test was performed with at least ten single discharges on the pre-selected points in the most sensitive polarity.

The time interval between two successive single discharges was at least 1 second.

The ESD generator was held perpendicularly to the surface to which the discharge was applied and the return cable was at least 0.2 meters from the EUT.

Contact discharges were applied to the non-insulating coating, with the pointed tip of the generator penetrating the coating and contacting the conducting substrate.

Air discharges were applied with the round discharge tip of the discharge electrode approaching the EUT as fast as possible (without causing mechanical damage) to touch the EUT. After each discharge, the ESD generator was removed from the EUT and re-triggered for a new single discharge. The test was repeated until all discharges were complete.

Vertical Coupling Plane (VCP):

The coupling plane of dimensions 0.5m x 0.5m, is placed parallel to and positioned at a distance 0.1m from the EUT, with the Discharge Electrode touching the coupling plane. The four faces of the EUT will be performed with electrostatic discharge.

Horizontal Coupling Plane (HCP):

The coupling plane is placed under to the EUT. The generator shall be positioned vertically at a distance of 0.1m from the EUT, with the Discharge Electrode touching the coupling plane.

The four faces of the EUT will be performed with electrostatic discharge.

- b. Air discharges at insulation surfaces of the EUT.  
It was at least ten single discharges with positive and negative at the same selected point.

### 4.3.3 TEST SETUP

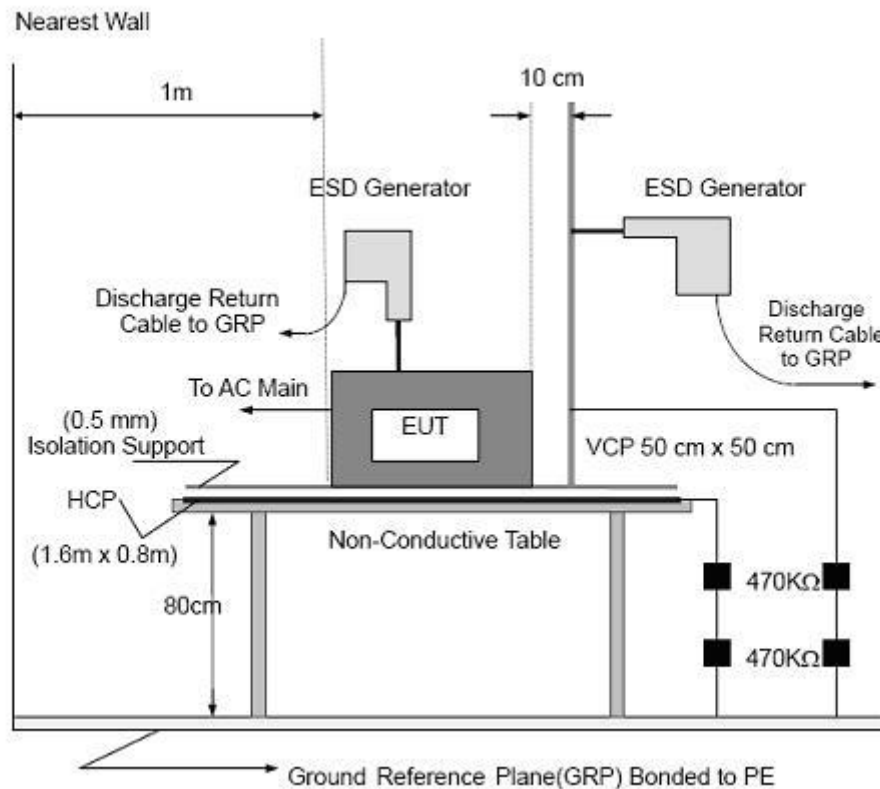

Note:

#### TABLE-TOP EQUIPMENT

The configuration consisted of a wooden table 0.8 meters high standing on the Ground Reference Plane. The GRP consisted of a sheet of aluminum at least 0.25mm thick. A Horizontal Coupling Plane (1.6m x 0.8m) was placed on the table and attached to the GRP by means of a cable with 940kΩ total impedance. The equipment under test, was installed in a representative system as described in section 7 of IEC /EN 61000-4-2, and its cables were placed on the HCP and isolated by an insulating support of 0.5mm thickness. A distance of 0.8-meter minimum was provided between the EUT and the walls of the laboratory and any other metallic structure.

#### FLOOR-STANDING EQUIPMENT

The equipment under test was installed in a representative system as described in section 7 of IEC/EN 61000-4-2, and its cables were isolated from the Ground Reference Plane by an insulating support of 0.1 meter thickness. The GRP was consisted of a sheet of aluminum that is at least 0.25mm thick, and extended at least 0.5 meters from the EUT on all sides.



#### 4.3.4 TEST RESULTS

Temperature:	25.3°C	Relative Humidity:	50%
Pressure:	1018.3hPa	Test Voltage:	AC 230V/50Hz
Test Mode:	Mode 1	Test Date:	2022.10.26

Discharge Level	Polarity	Test Points	Contact Discharge	Air Discharge	Criterion	Test Result
2,4	+/-	VCP/HCP	NOTE	N/A	B	A
2,4	+/-	Green Dot	NOTE	N/A	B	A
2,4,8	+/-	Red Dot	NA	NOTE	B	A

Note: The EUT function was correct during the test  
Red Dot —Air Discharged  
Green Dot —Contact Discharged

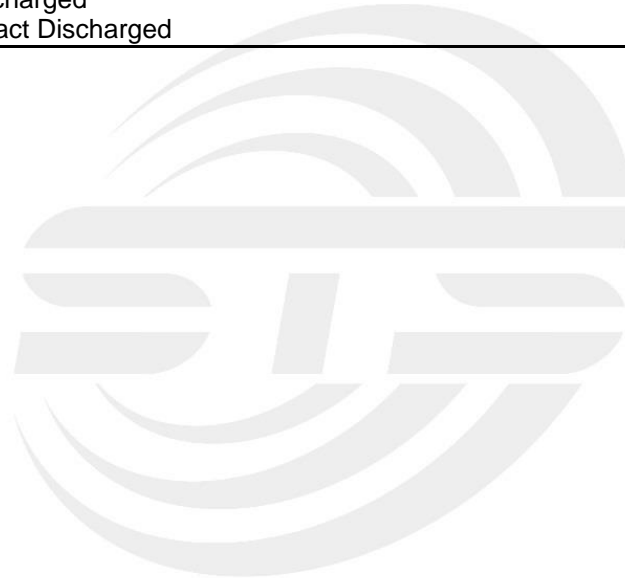



### The Photo for Discharge Points of EUT





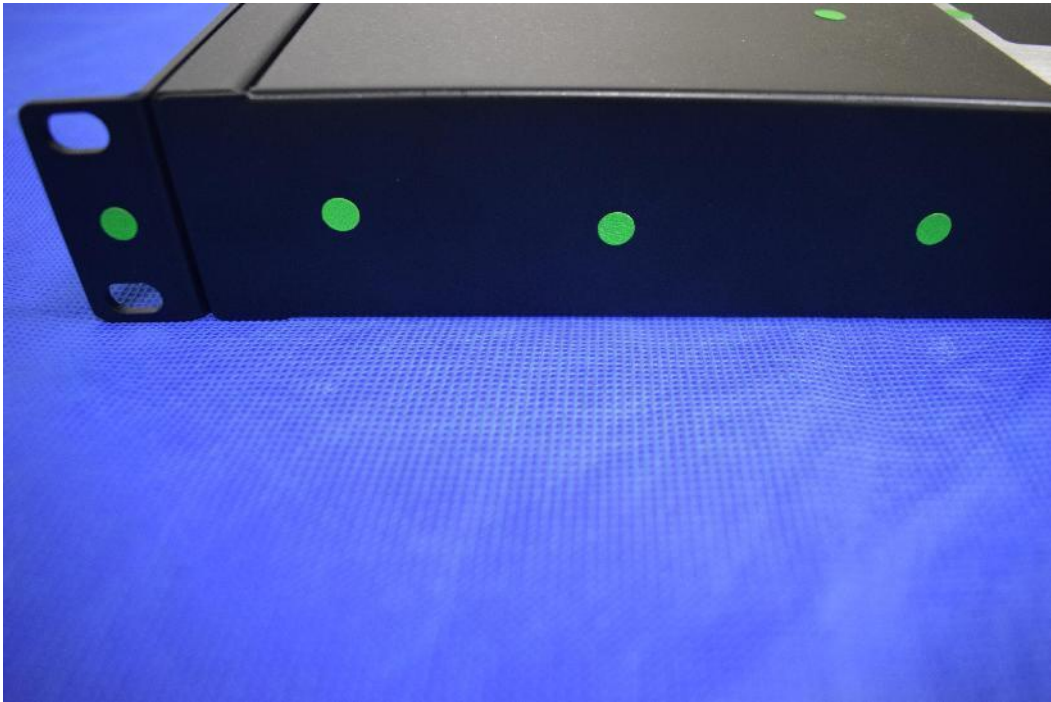



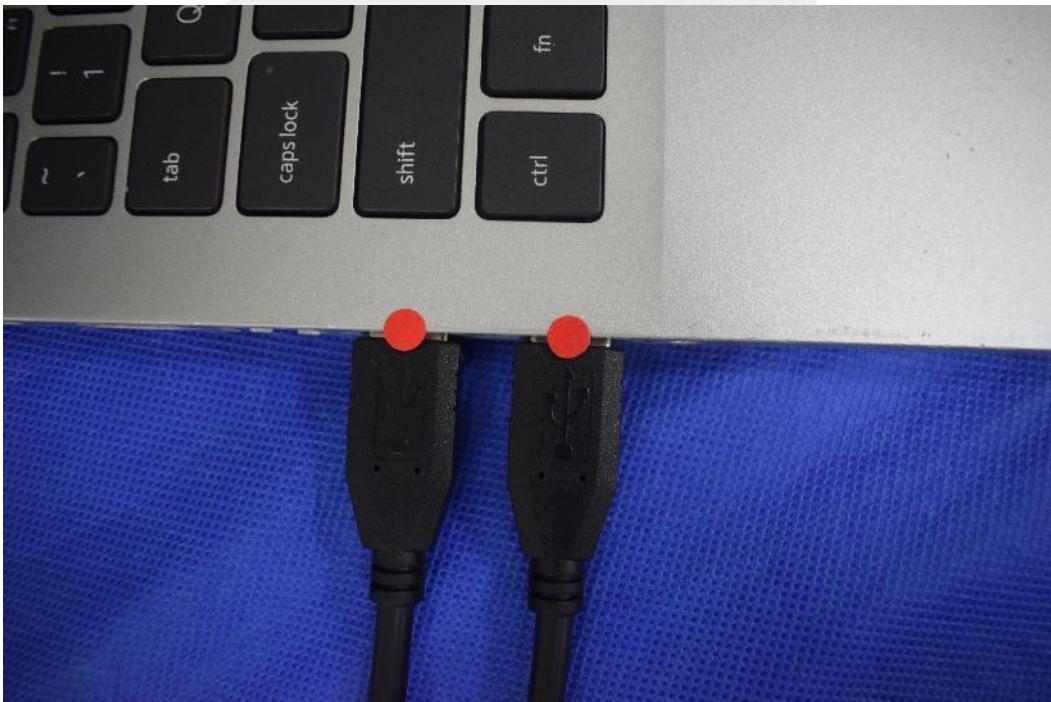
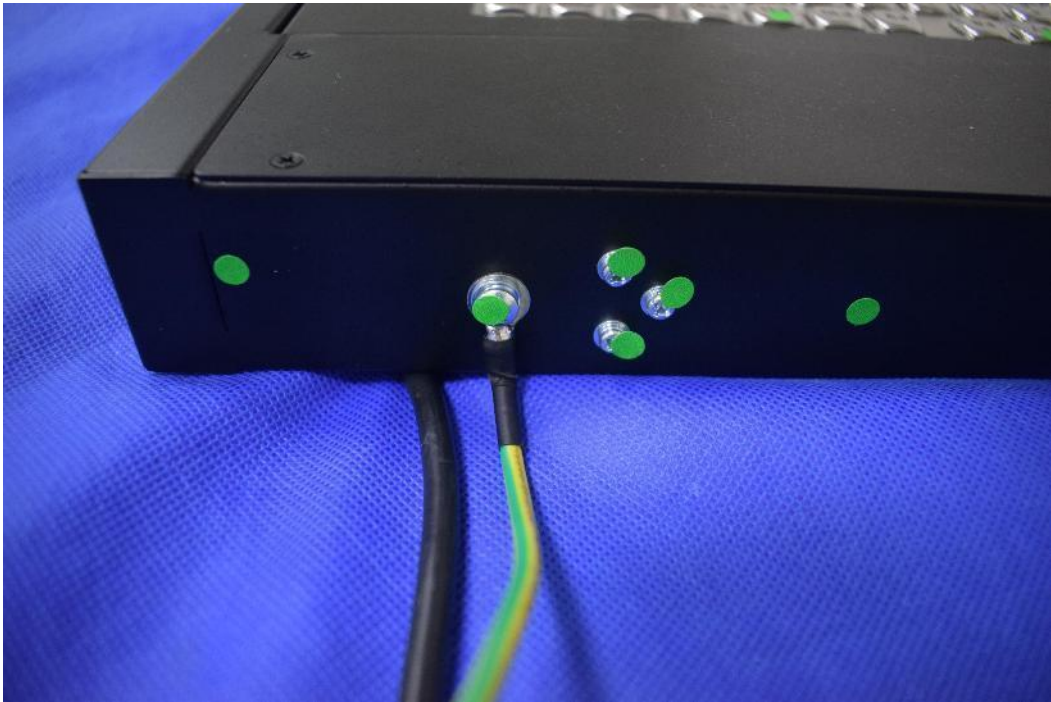



#### 4.4 RADIATED, RADIO-FREQUENCY, ELECTROMAGNETIC FIELD IMMUNITY TEST (RS)

##### 4.4.1 TEST SPECIFICATION

Basic Standard:	IEC/EN 61000-4-3
Required Performance:	A
Frequency Range:	80 MHz - 1000 MHz 1.4 GHz - 6 GHz
Field Strength:	10 V/m, 3 V/m, 1 V/m,
Modulation:	1kHz Sine Wave, 80%, AM Modulation
Frequency Step:	1 % of fundamental
Polarity of Antenna:	Horizontal and Vertical
Test Distance:	3 m
Antenna Height:	1.5 m
Dwell Time:	3s

##### 4.4.2 TEST PROCEDURE

- a. The testing was performed in a fully anechoic chamber. The transmit antenna was located at a distance of 3 meters from the EUT.
- b. The frequency range is swept from 80 MHz to 1000 MHz, 1.4 GHz - 2.0 GHz, 2.0 GHz - 2.7 GHz with the signal 80% amplitude modulated with a 1kHz sine-wave. The rate of sweep did not exceed 3s, where the frequency range is swept incrementally, the step size was 1% of preceding frequency value.
- c. The dwell time at each frequency shall be not less than the time necessary for the EUT to be able to respond.
- e. The test was performed with the EUT exposed to both vertically and horizontally polarized fields on each of the four sides.

#### 4.4.3 TEST SETUP

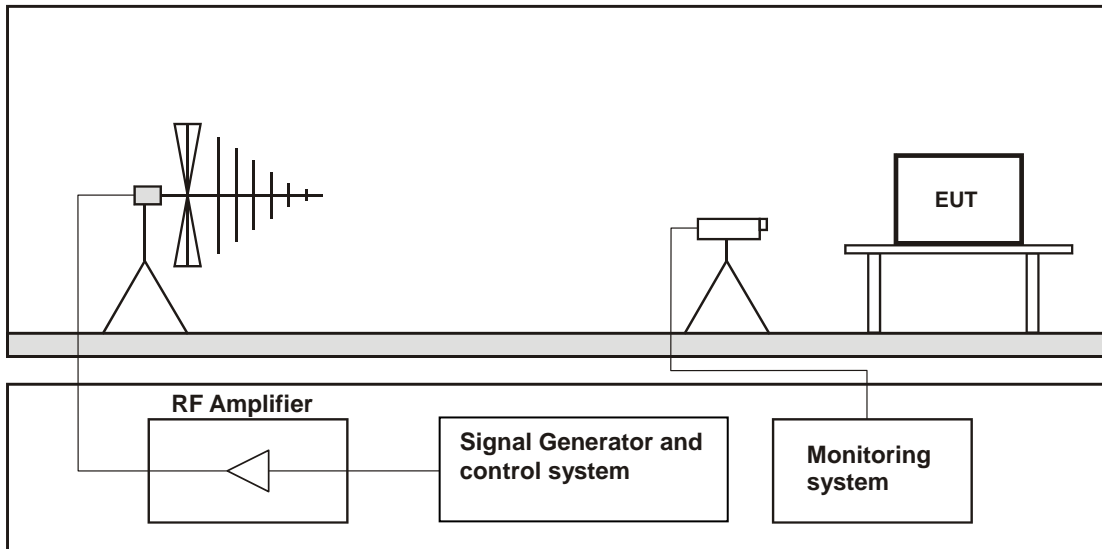

Note:

##### TABLE-TOP EQUIPMENT

The EUT installed in a representative system as described in section 7 of IEC/EN 61000-4-3 was placed on a non-conductive table 0.8 meters in height. The system under test was connected to the power and signal wire according to relevant installation instructions.

##### FLOOR-STANDING EQUIPMENT

The EUT installed in a representative system as described in section 7 of IEC/EN 61000-4-3 was placed on a non-conductive wood support 0.1 meters in height. The system under test was connected to the power and signal wire according to relevant installation instructions.



**4.4.4 TEST RESULTS**

Temperature:	25.3°C	Relative Humidity:	50%
Test Voltage:	AC 230V /50Hz	Test Date:	2022.10.26
Test Mode:	Mode1		

Frequency Range (MHz)	RF Field Position	R.F. Field Strength	Azimuth	Perform. Criteria	Results	Judgment
80MHz - 1000MHz	H / V	10 V/m (rms) AM Modulated 1000Hz, 80%	Front	A	A	PASS
			Rear			
			Left			
			Right			
1.4 GHz – 6.0 GHz	H / V	3 V/m (rms) AM Modulated 1000Hz, 80%	Front	A	A	PASS
			Rear			
			Left			
			Right			
			Left			
			Right			



## 4.5 ELECTRICAL FAST TRANSIENT (EFT)

### 4.5.1 TEST SPECIFICATION

Basic Standard:	IEC/EN 61000-4-4
Required Performance:	B
Test Voltage:	Power Line: 2 KV DC Line: 2 KV Signal/Control Line: 1 KV
Polarity:	Positive & Negative
Impulse Frequency:	5 kHz
Impulse Wave shape :	5/50 ns
Burst Duration:	15ms
Burst Period:	300ms
Test Duration:	Not less than 1 min.

### 4.5.2 TEST PROCEDURE

The EUT and support equipment, are placed on a table that is 0.8 meter&0.1 meter above a metal ground plane measured 1m\*1m min .

The ground reference plane shall be a metallic sheet (copper or aluminum) of 0.25 mm minimum thickness; other metallic materials may be used , but they shall have at least 0.65 mm minimum thickness.

The other condition need as following manners:

- a. The length of power cord between the coupling device and the EUT should not exceed 1 meter.
- b. Both positive and negative polarity discharges were applied.
- c. The duration time of each test sequential was 1 minute.

### 4.5.3 TEST SETUP

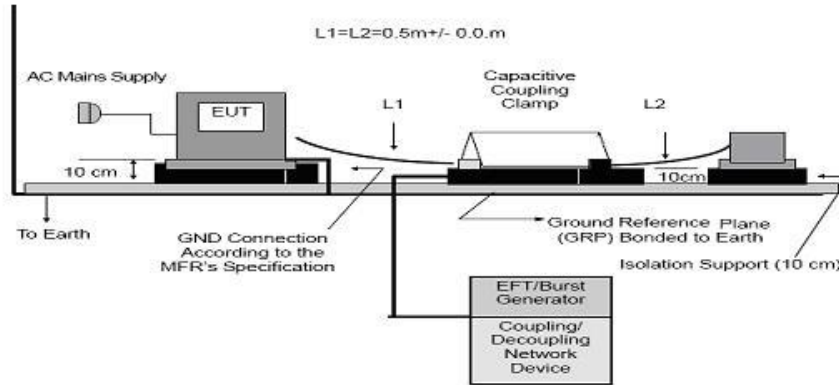
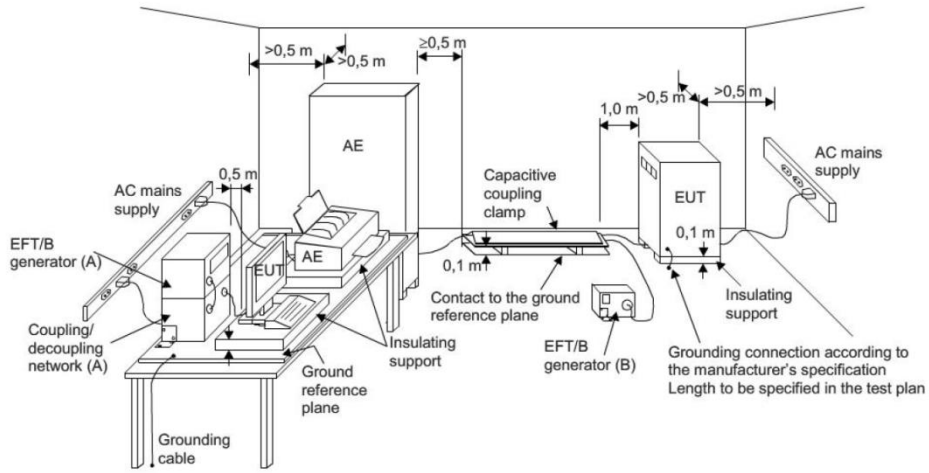





Note:

#### TABLE-TOP EQUIPMENT

Table-top equipment and equipment normally mounted on ceilings or walls as well as built-in equipment shall be tested with the EUT located ( $0.1 \pm 0.01$ ) m above the ground reference plane.

Testing of large table-top equipment or multiple systems can be performed on the floor; maintaining the same distances as for the test setup of table-top equipment.

The test generator and the coupling/decoupling network shall be bonded to the ground reference plane.

The ground reference plane shall be a metallic sheet (copper or aluminum) of 0.25mm minimum thickness; other metallic materials may be used, but they shall have at least 0.65 mm minimum thickness.

The minimum size of the ground reference plane is 0.8m x 1m. The actual size depends on the dimensions of the EUT.

The ground reference plane shall project beyond the EUT by at least 0.1m on all sides.

The ground reference plane shall be connected to the earth (PE) for safety reasons.

The EUT shall be arranged and connected to satisfy its functional requirements, according to the equipment installation specifications.

The minimum distance between the EUT and all other conductive structures (including the generator, AE and the walls of a shielded room), except the ground reference plane, shall be more than 0.5m.

All cables to the EUT shall be placed on the insulation support 0.1m above the ground reference plane. Cables not subject to electrical fast transients shall be routed as far as possible from the cable under test to minimize the coupling between the cables.

The EUT shall be connected to the earth system in accordance with the manufacturer's installation specifications; no additional earth connections are allowed.

The connection impedance of the coupling/decoupling network earth cables to the ground reference plane and all connectors shall provide a low inductance.

Either a direct coupling network or a capacitive clamp shall be used for the application of the test voltages. The test voltages shall be coupled to all of the EUT ports in turn including those between two units of equipment involved in the test, unless the length of the interconnecting cable makes it impossible to test.

#### FLOOR-STANDING EQUIPMENT

When using the coupling clamp, the minimum distance between the coupling plates and all other conductive surfaces (including the generator), except the ground reference plane beneath the coupling clamp and beneath the EUT, shall be at least 0.5m.

The distance between any coupling devices and the EUT shall be ( $0.5 - 0/+0.1$ ) m for tabletop equipment testing, and ( $1.0 \pm 0.1$ ) m for floor standing equipment, unless otherwise specified in product standards. When it is not physically possible to apply the distances mentioned above, other distances can be used and shall be recorded in the test report.

The cable between the EUT and the coupling device, if detachable, shall be as short as possible to comply with the requirements of this clause. If the manufacturer provides a cable exceeding the distance between the coupling device and the point of only of the EUT, the excess length of this cable shall be bundled and situated at a distance of 0,1m above the ground reference plane.

When a capacitive clamp is used as a coupling device, the excess cable length shall be bundled at the AE side.

Parts of the EUT with interconnecting cables of a length less than 3m, which are not tested, shall be placed on the insulating support. The parts of the EUT shall have a distance of 0,5m between them. Excess cable length shall be bundled.





#### 4.5.4 TEST RESULTS

Temperature:	25.3°C	Relative Humidity:	50%
Test Voltage:	AC 230V /50Hz	Test Date:	2022.10.26
Test Mode:	Mode1		

Coupling Line		Test level	Perform. Criteria	Results	Judgment
AC line	L	±2KV	B	A	PASS
	N	±2KV		A	PASS
	PE	±2KV		A	PASS
	L+N	±2KV		A	PASS
	L+PE	±2KV		A	PASS
	N+PE	±2KV		A	PASS
	L+N+PE	±2KV		A	PASS
DC Line		N/A		N/A	N/A
Signal Line		N/A		N/A	N/A

Note: 1) N/A - denotes test is not applicable in this test report.



## 4.6 SURGE TESTING

### 4.6.1 TEST SPECIFICATION

Basic Standard:	IEC/EN 61000-4-5
Required Performance:	B
Wave-Shape:	Combination Wave 1.2/50us Open Circuit Voltage
Test Voltage:	Power line ~ line to line: 1 KV line to ground: 2 KV DC line: 0.5 KV line to ground: 1 KV
Surge Input/Output:	L-N, L-PE, N-PE
Generator Source:	(L-N)2 ohm between networks
Impedance:	(L-PE, N-PE)12 ohm between network and ground
Polarity:	Positive/Negative
Phase Angle:	0°/90°/180°/270°
Pulse Repetition Rate:	1 time / min. (maximum)
Number of Tests:	5 positive and 5 negative at selected points

### 4.6.2 TEST PROCEDURE

a. For EUT power supply:

The surge is to be applied to the EUT power supply terminals via the capacitive coupling network. Decoupling networks are required in order to avoid possible adverse effects on equipment not under test that may be powered by the same lines, and to provide sufficient decoupling impedance to the surge wave. The power cord between the EUT and the coupling/decoupling networks shall be 2meters in length (or shorter).

b. For test applied to unshielded unsymmetrical operated interconnection lines of EUT:

The surge is applied to the lines via the capacitive coupling. The coupling /decoupling networks shall not influence the specified functional conditions of the EUT. The interconnection line between the EUT and the coupling/decoupling networks shall be 2 meters in length (or shorter).

### 4.6.3 TEST SETUP

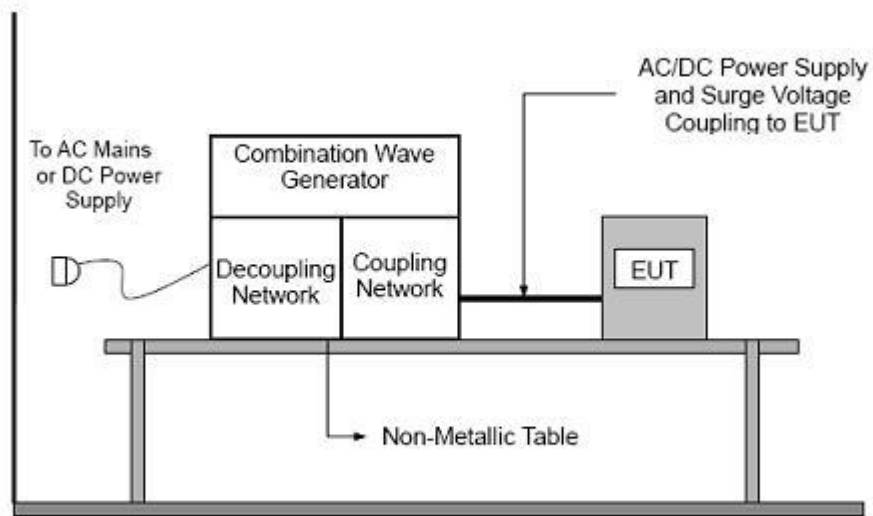



4.6.4 TEST RESULTS

Temperature:	25.3°C	Relative Humidity:	50%
Test Voltage:	AC 230V /50Hz	Test Date:	2022.10.26
Test Mode:	Mode 1		

Coupling Line			Test level								Criterion	Result
			0.5 kV		1 kV		2 kV		4 kV			
			+	-	+	-	+	-	+	-		
AC line	L-N	0°			A	A					B	PASS
		90°			A	A						PASS
		180°			A	A						PASS
		270°			A	A						PASS
	L-PE	0°					A	A				PASS
		90°					A	A				PASS
		180°					A	A				PASS
		270°					A	A				PASS
	N-PE	0°					A	A				PASS
		90°					A	A				PASS
		180°					A	A				PASS
		270°					A	A				PASS
Signal Line	Line-Line											
	Line-Ground											
DC Line	Line-Line											
	Line-Ground											



## 4.7 CONDUCTED RADIO FREQUENCY DISTURBANCES (CS)

### 4.7.1 TEST SPECIFICATION

Basic Standard:	IEC/EN 61000-4-6
Required Performance:	A
Frequency Range:	0.15 MHz - 80 MHz
Field Strength:	10Vr.m.s.
Modulation:	1kHz Sine Wave, 80%, AM Modulation
Frequency Step:	1 % of fundamental
Dwell Time:	3s

### 4.7.2 TEST PROCEDURE

The EUT shall be tested within its intended operating and climatic conditions.

The test shall be performed with the test generator connected to each of the coupling and decoupling devices in turn, while the other non-excited RF input ports of the coupling devices are terminated by a 50-ohm load resistor.

The frequency range was swept from 150 kHz to 80 MHz, using the signal level established during the setting process and with a disturbance signal of 80 % amplitude. The signal was modulated with a 1 kHz sine wave, pausing to adjust the RF signal level or the switch coupling devices as necessary. The sweep rate was 3s. Where the frequency range is swept incrementally, the step size was 1 % of preceding frequency value from 150kHz to 80MHz.

The dwell time at each frequency was less than the time necessary for the EUT to be exercised, and able to respond. Sensitive frequencies such as clock frequency (ies) and harmonics or frequencies of dominant interest, was analyzed separately.

Attempts were made to fully exercise the EUT during testing, and to fully interrogate all exercise modes selected for susceptibility.

### 4.7.3 TEST SETUP

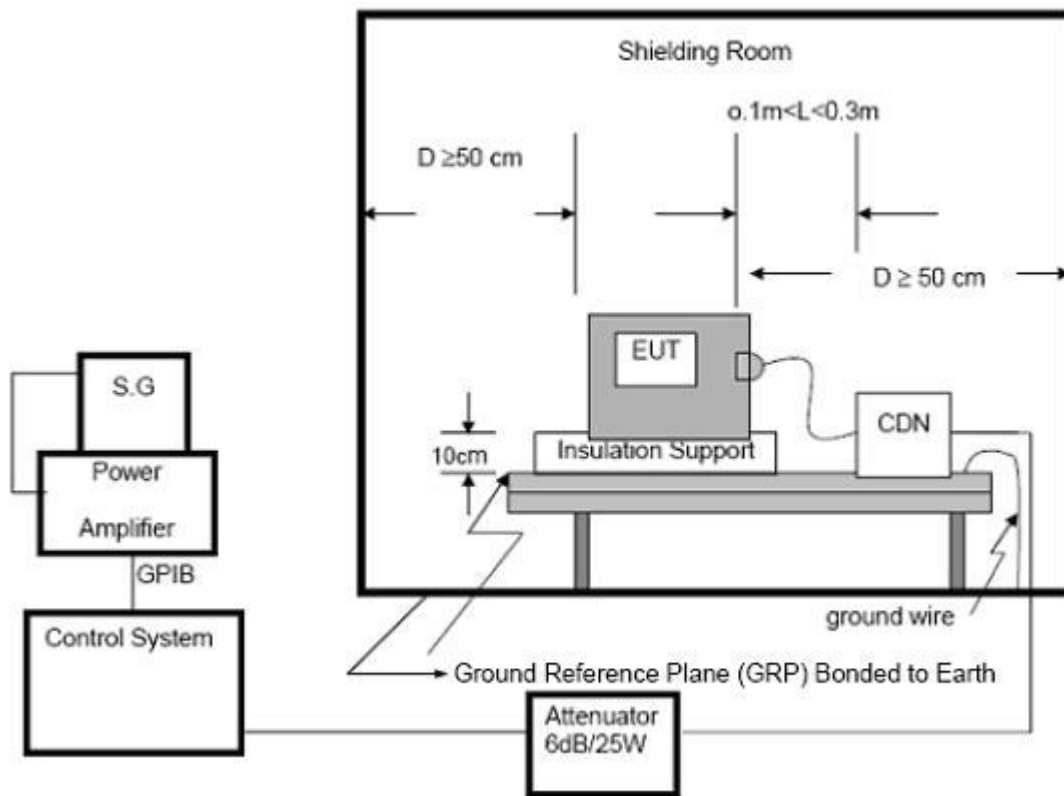

**NOTE:  
FLOOR-STANDING EQUIPMENT**

The equipment to be tested is placed on an insulating support of 0.1 meters height above a ground reference plane. All relevant cables shall be provided with the appropriate coupling and decoupling devices at a distance between 0.1 meters and 0.3 meters from the projected geometry of the EUT on the ground reference plane.



#### 4.7.4 TEST RESULTS

Temperature:	25.3°C	Relative Humidity:	50%
Test Voltage:	AC 230V /50Hz	Test Date:	2022.10.26
Test Mode:	Mode 1		

Test Ports (Mode)	Freq. Range (MHz)	Field Strength	Perform. Criteria	Results	Judgment
Input/ Output AC. Power Port	0.15 - 80	10V(rms) AM Modulated 1000Hz, 80%	A	A	PASS
Input/ Output DC. Power Port	0.15 - 80		N/A	N/A	N/A
Control Line	0.15 ---80		N/A	N/A	N/A
Signal Line	0.15 - 80		N/A	N/A	N/A

Note: 1) N/A - denotes test is not applicable in this test report.



## 4.8 VOLTAGE INTERRUPTION/DIPS TESTING (DIPS)

### 4.8.1 TEST SPECIFICATION

Basic Standard:	IEC/EN 61000-4-11
Required Performance:	B (For 100% Voltage Dips, 0.5 Cycle) C (For 30% Voltage Dips, 25 Cycles) C (For 100% Voltage Interruptions, 250 Cycles)
Test Duration Time:	Minimum three test events in sequence
Interval between Event:	Minimum ten seconds
Phase Angle:	0°/45°/90°/135°/180°/225°/270°/315°/360°
Test Cycle:	3 times

### 4.8.2 TEST PROCEDURE

The EUT shall be tested for each selected combination of test levels and duration with a sequence of three dips/interruptions with intervals of 10 s minimum (between each test event). Each representative mode of operation shall be tested. Abrupt changes in supply voltage shall occur at zero crossings of the voltage waveform.

### 4.8.3 TEST SETUP

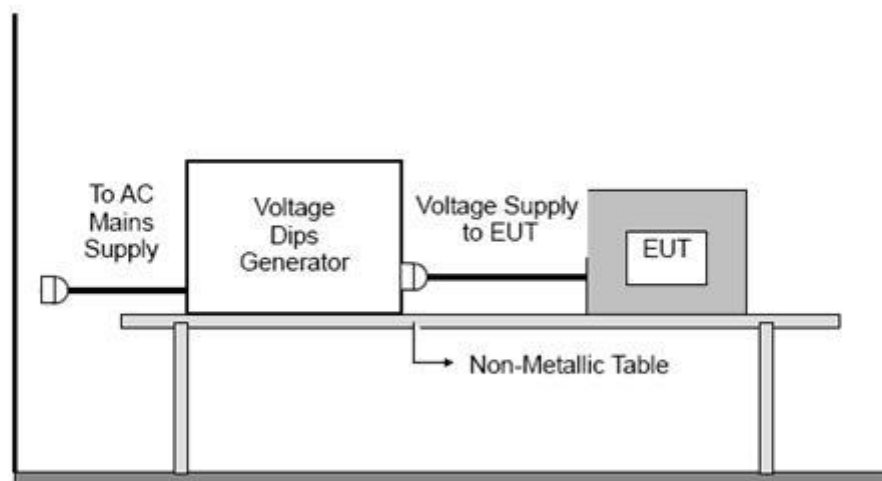



#### 4.8.4 TEST RESULTS

Temperature:	25.3°C	Relative Humidity:	50%
Test Voltage:	AC 230V /50Hz	Test Date:	2022.10.26
Test Mode:	Mode 1		

Interruption & Dips	Duration (T)	Perform Criteria	Results	Judgment
Interruption 0%	1	B	A	PASS
Voltage dip 40%	10	B	A	PASS
Voltage dip 70%	25	C	A	PASS
Interruption 0%	250	C	A	PASS



## APPENDIX 1- TEST SETUP

RE (30 - 1000 MHz )

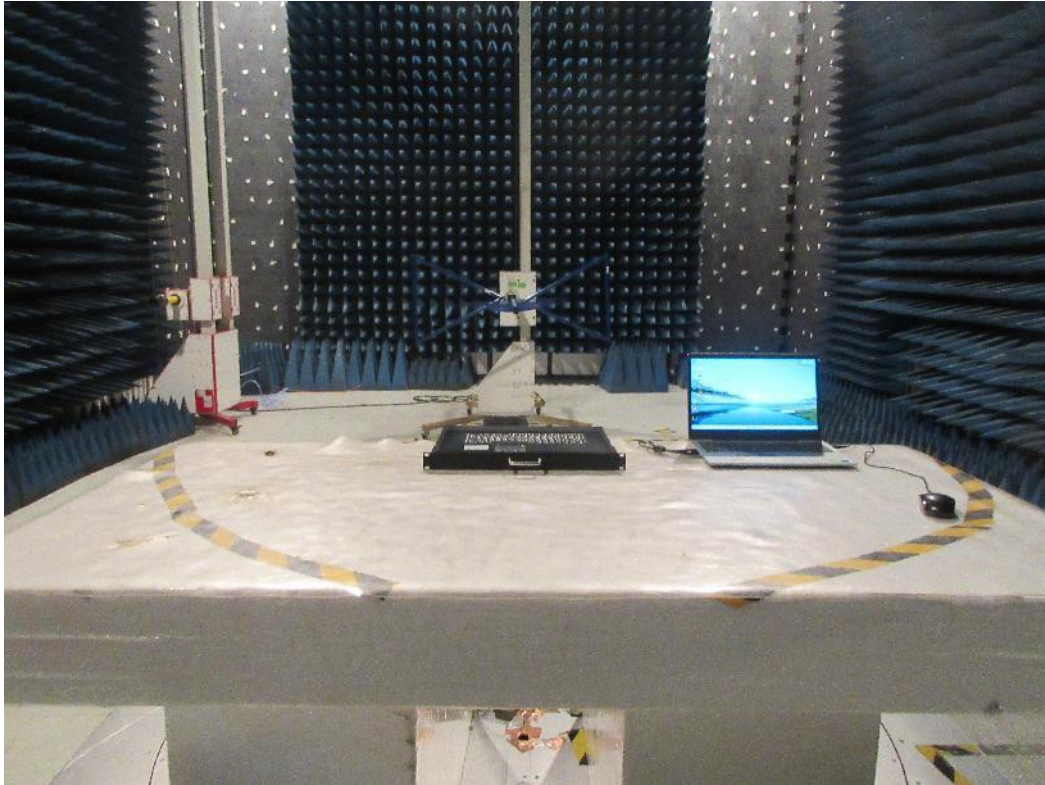

CE



### FLICKER



### SURGE





### EFT



### DIPS



ESD



CS





**RS (80 - 1000 MHz)**

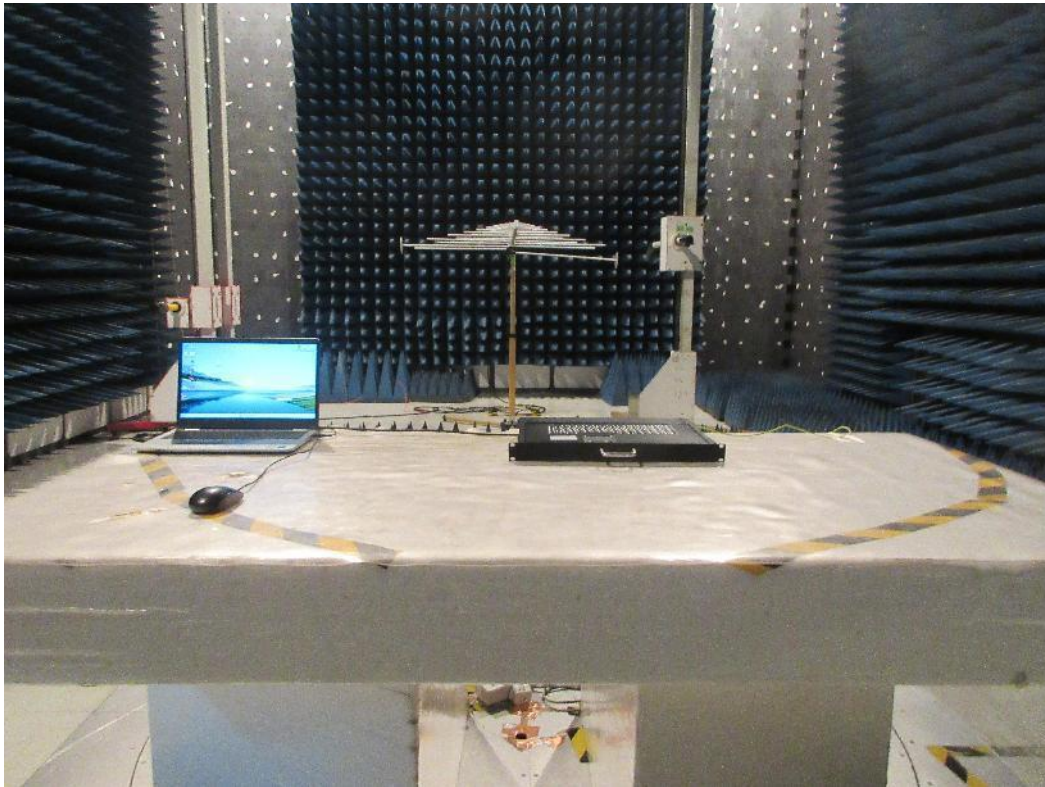

**RS (1000 - 6000 MHz)**



※※※※ END OF THE REPORT ※※※※